

## Description

The CPA and CPD Series are highly reliable power supplies for CompactPCI® systems, which are increasingly used in communications, industrial, military, aerospace, and other applications. These power supplies offer high power density in plug-in modules that meet the requirements of the PICMG® power interface specification for CompactPCI® systems.

The converters use the patented EDGE™ technology and provide important advantages such as flexible output power, extremely high efficiency, excellent reliability, full input-to-output isolation, negligible inrush current, hot-swap capability, soft start, and overtemperature protection.

The inputs are protected against surges and transients occurring on the source lines and cover an operating input voltage range from either 90 to 264 VAC or 36 to 75 VDC. Voltage suppressor diodes protect the input against overvoltage.

## Features

**Compliant with PICMG® CompactPCI® specifications**  
**Input-to-output isolation**  
**4 high current outputs**

- RoHS lead-free-solder and lead-solder-exempted products are available
- Wide range DC or AC input with PFC
- Extremely high efficiency and high power density
- Low inrush current
- Flexible load distribution
- Integrated ORing FETs / diodes for true redundancy
- Inhibit and enable inputs
- Remote sense lines
- Single-wire current share for 3 outputs
- Hot-swap capability
- Positronic 47-pin connector
- Overtemperature, overvoltage, overcurrent, and overpower protection

Safety according to IEC/EN 60950-1 and UL 60950-1



## Table of Contents

	Page		Page
Description .....	1	Electromagnetic Compatibility (EMC) .....	13
Model Selection .....	2	Immunity to Environmental Conditions .....	15
Functional Description .....	3	Mechanical Data .....	16
Electrical Input Data .....	5	Safety and Installation Instructions .....	17
Electrical Output Data .....	7	Declaration of Conformity CPD .....	19
Auxiliary Functions .....	10	Declaration of Conformity CPA .....	20

The outputs are protected against continuous overload, open-circuit, and short-circuit. Full n+1 redundant operating mode is made possible by integrated ORing FETs/diodes. When several converters are connected in parallel, a single-wire connection between converters ensures current sharing. The converters are designed as two separate forward converters with synchronous rectifiers at the outputs. The switching frequency is fixed at approx. 135 kHz.

LEDs on the front panel, a temperature warning signal, and a fail signal display the status of the power supply. The aluminium case acts as a heat sink and as an RFI shield. It is particularly suitable for vertical insertion into 19" rack systems, but it can also be mounted in any other position as long as the necessary airflow is ensured. The connector is a 47-pin type from Positronic.

## Model Selection

Table 1: Standard models

Model <sup>3</sup>	Output				Operating input range	Rated power <sup>1</sup>	Efficiency <sup>2</sup>		Case
	No.	$V_{o\ nom}$ [V]	$I_{o\ nom}$ [A]	$I_{o\ max}$ [A]			$V_{i\ min} - V_{i\ max}$	$P_{o\ nom}$ <sup>1</sup> [W]	
CPD200-4530G CPD200-4530	Vo1 Vo2 Vo3 Vo4	5.0 3.3 12 -12	20 20 2.5 0.5	40 40 5.5 2	36 – 75 VDC	200	80	82.2	3U x 8HP
CPD250-4530G CPD250-4530	Vo1 Vo2 Vo3 Vo4	5.0 3.3 12 -12	25 20 4 1	40 40 5.5 2	36 – 75 VDC	250	80	82.2	3U x 8HP
CPA200-4530G CPA200-4530	Vo1 Vo2 Vo3 Vo4	5.0 3.3 12 -12	20 20 2.5 0.5	40 40 5.5 2	90 – 264 VAC <sup>4)</sup> 47 – 63 Hz <sup>5)</sup>	200	81.5	83	3U x 8HP
CPA250-4530G CPA250-4530	Vo1 Vo2 Vo3 Vo4	5.0 3.3 12 -12	25 20 4 1	40 40 5.5 2	90 – 264 VAC <sup>4)</sup> 47 – 63 Hz <sup>5)</sup>	250	81.5	82.6	3U x 8HP
CPA500-4530G CPA500-4530	Vo1 Vo2 Vo3 Vo4	5.0 3.3 12 -12	40 50 8 3	50 60 12 4	90 – 264 VAC <sup>4)</sup> 47 – 63 Hz <sup>5)</sup>	500	83	84.3	6U x 8HP
CPA550-4530G CPA550-4530	Vo1 Vo2 Vo3 Vo4	5.0 3.3 12 -12	50 50 8 3	50 60 12 4	90 – 264 VAC <sup>4)</sup> 47 – 63 Hz <sup>5)</sup>	550	83	84.5	6U x 8HP

<sup>1</sup> The sum of the power of all outputs may not exceed the total power for the specified required forced-air cooling.

<sup>2</sup> Efficiency at  $T_A = 25\ ^\circ\text{C}$ ,  $V_{i\ nom}$ ,  $I_{o\ nom}$ .

<sup>3</sup> Models ending with G are RoHS-compliant for all 6 substances.

<sup>4</sup> Rated input voltage range is 100 – 240 VAC.

<sup>5</sup> Rated input frequency range is 50 – 60 Hz.

## Product Marking

Label with specific type designation, applicable safety approvals and recognition marks, CE mark, warnings, Power-One patents, company logo, input voltage range, nominal output voltage and output current, degree of protection, batch no., serial no., and data code including production site, modification status, and date of production.

Identification of LEDs.

## Functional Description

The converter input is protected against surges and transients occurring on the source lines. The highly efficient input filter and the active inrush current limiter ensure a very low inrush current of short duration. This prevents circuit breakers and fuses from tripping at switch-on.

All CPA models have an additional bridge rectifier and a boost converter to provide active power factor correction.

The power supply is equipped with two independent high efficiency 2-switch forward converters, switching 180° out of phase to minimize ripple current at the input. Both forward converters are fully regulated.

On the secondary side, two high current synchronous rectifiers supply the 5 V and 3.3 V outputs with up to 60 A. The secondary controlled +12 V post regulator is supplied by an additional winding of the 3.3 V main transformer, and the linear regulator for the -12 V output is supplied by the output choke of the +12 V output. After rectification, the output filter reduces ripple and noise to a minimum without compromising the dynamic response.

All outputs are protected from the bus by decoupling FETs or diodes. A current monitor calculates the output power. As

soon as the output power exceeds the maximum threshold level, the converter starts to reduce the output power by decreasing the output voltages.

In contrast to the outputs Vo1 (5 V), Vo2 (3.3 V), and Vo3 (+12 V) with active current sharing, output Vo4 (-12 V) has a droop characteristic for passive current sharing. Each converter operates with a switching frequency of around 135 kHz.

Power-One's Efficient Dual Geometric Edge Technology (EDGE<sup>™</sup>) facilitates high current density, increases reliability by reducing component stresses, and decreases the amount of heat dissipated. The backbone of this patented technology is an interleaved, multi-channel forward converter utilising a transitional resonant switching technique and proprietary leading and trailing-edge pulse width modulation. It has a proven track record in high-availability power solutions.

CPA500/550 models have an additional forward converter for the outputs Vo3 (+12 V) and Vo4 (-12 V). All outputs are fully regulated; see fig. 1b.

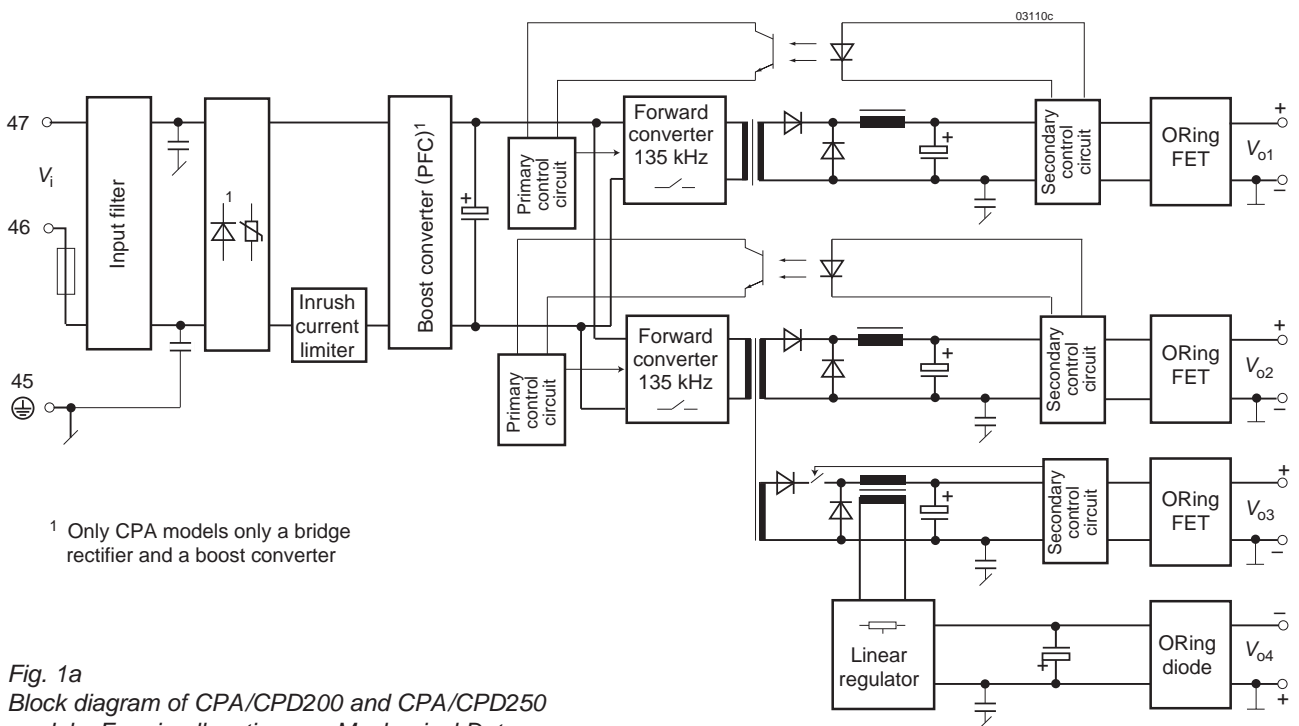

**Fig. 1a**  
Block diagram of CPA/CPD200 and CPA/CPD250 models. For pin allocation see Mechanical Data.

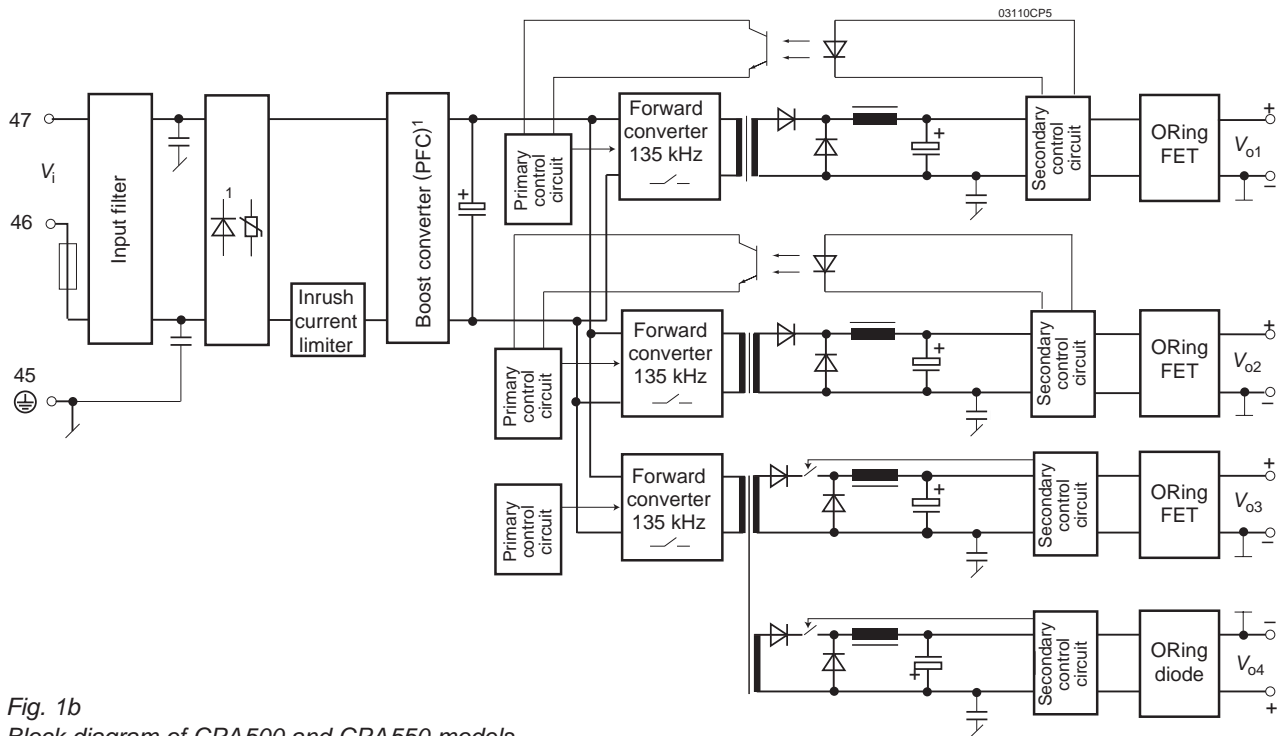

Fig. 1b  
Block diagram of CPA500 and CPA550 models.  
For pin allocation see Mechanical Data.

## Electrical Input Data

General Conditions:

$T_A = 25\text{ °C}$ , unless  $T_C$  is specified.

Table 2a: Input data of CPD models

Input			CPD200			CPD250			Unit
Characteristics	Conditions	min	typ	max	min	typ	max		
$V_i$	Operating input voltage	$I_o = 0 - I_{o\ max}$		36	75		36	75	VDC
$V_{i\ nom}$	Nom. input voltage	$T_C\ min - T_C\ max$		48		48			
$V_{i\ abs}$	Input voltage limits	without damage		80		80			
$I_i$	Typical input current	$V_{i\ nom}, I_{o\ nom}$		5.1		6.3		A	
$I_{i\ max}$	Max. input current	$V_{i\ min}, I_{o\ nom}$		7.0	7.6	8.7	9.5		
$I_{i\ nr\ p}$	Peak inrush current	$V_{i\ max}, I_{o\ nom}$		12		12			
$P_{i0}$	No-load input power	$V_{i\ min} - V_{i\ max}$ $I_o = 0$		30		30		W	
$P_{i\ inh}$	Input power, when disabled	$V_{i\ min} - V_{i\ max}$		3.2		3.2			
$C_i$	Input capacitance			1360		1360		μF	
$f_{switch}$	Switching frequency	$V_{i\ nom}, I_{o\ nom}$		135		135		kHz	
$t_h$	Hold-up time	$V_{i\ nom} \rightarrow 0\ V, I_{o\ nom}$		4			4	ms	
$t_{su}$	Start-up time	$V_{i\ nom}, I_{o\ nom}$		150	200	150	200		

Table 2b: Input data of CPA models

Input			CPA200/250			CPA500/550			Unit
Characteristics	Conditions	min	typ	max	min	typ	max		
$V_i$	Rated input voltage range	$I_o = 0 - I_{o\ max}$		100	240		100	240	VAC <sup>1</sup>
$V_{i\ op}$	Operating input voltage	$T_C\ min - T_C\ max$		90	264		90	264	
$V_{i\ nom}$	Nom. input voltage	50 – 60 Hz <sup>1</sup>		230		230			
$V_{i\ abs}$	Input voltage limits	without damage		280		280			
$I_i$	Typical input current	$V_{i\ nom}, I_{o\ nom}$		1.1/1.4 <sup>2</sup>		2.8/3.1 <sup>3</sup>		A	
$I_{i\ max}$	Max. input current	$V_{i\ min}, I_{o\ nom}$		2.9/3.6 <sup>2</sup>	3.2/4.0 <sup>2</sup>	7.1/7.8 <sup>3</sup>			
$I_{i\ nr\ p}$	Peak inrush current	$V_{i\ max}, I_{o\ nom}$		15		20			
$P_{i0}$	No-load input power	$V_{i\ min} - V_{i\ max}$ $I_o = 0$		30		32		W	
$P_{i\ inh}$	Input power, when disabled	$V_{i\ min} - V_{i\ max}$		3.2		3.2			
$C_i$	Input capacitance			1		4		μF	
$f_{switch}$	Switching frequency	$V_{i\ nom}, I_{o\ nom}$		135		135		kHz	
$t_h$	Hold-up time	$V_{i\ nom} \rightarrow 0\ V, I_{o\ nom}$		20			20	ms	
$t_{su}$	Start-up time <sup>4</sup>	$V_{i\ nom}, I_{o\ nom}$		150		150			
	Power factor	$V_{i\ nom}, I_{o\ nom}$		0.95		0.95		W/VA	

<sup>1</sup> Rated input frequency: 50 – 60 Hz, operating input frequency range: 47 – 63 Hz

<sup>2</sup> First value for CPA200, 2<sup>nd</sup> value for CPA250

<sup>3</sup> First value for CPA500, 2<sup>nd</sup> value for CPA550

<sup>4</sup> Required for initial output voltage stabilization

### Input Transient Protection

A metal oxide VDR (Voltage Dependent Resistor) together with the input fuse form an effective protection against high input voltage transients, which typically occur in most installations.

### Input Fuse

An incorporated miniature slow-blow fuse protects the converter against further damage in the case of a failure.

Reverse polarity applied to the input of CPD models will cause the fuse to blow but without other damage.

**Note:** The fuse is not customer-accessible.

Table 3: Fuse specification

Model	Fuse rating	Reference
CDP200/250	250 V, 12.5 A T	Schurter 0001.2515
CPA200/250	250 VAC, 5 A T	Schurter 0001.2511
CPA500/550	250 VAC, 10 A T	Schurter 0034.6925

### Inrush Current Limitation

The converters incorporate an active inrush current limiter in the input circuitry, which reduces the peak inrush current value by a factor of 10 – 15 to protect connectors and switching devices from damage.

**Note:** The inrush current limitation is achieved using electronic circuitry. For effective limitation the converter should not be switched on and off more frequently than every 8 seconds.

### Reverse Polarity

To avoid unwanted power losses, the CPD Series converters are not protected against reverse polarity at the input. In case of reversed input voltage, the input suppressor diode will be conducting and trigger the input fuse to blow; however no further damage will occur.

The CPA Series converters are designed for AC input and have a rectifier bridge on the input.

### Efficiency

The efficiency is specified in table 1. Figure 2 shows the dependence on input voltage (CPA models). The efficiency of CPD models depends only marginally on input voltage.

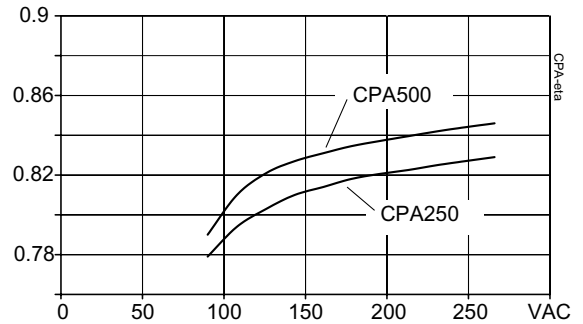

Fig. 2  
CPA Series: Efficiency versus input voltage

## Electrical Output Data

General Conditions:

–  $T_A = 25\text{ }^\circ\text{C}$ , unless  $T_C$  is specified.

– CPD/CPA200: 250 LFM (1.25 m/s), CPD/CPA250: 400 LFM (2 m/s)

– Sense lines connected directly at the connector

Table 4a: Output data of CPD/CPA200 and CPD/CPA250

Output			Vo1 (5.0 V)			Vo2 (3.3 V)			Unit
Characteristics		Conditions	min	typ	max	min	typ	max	
$V_o$	Output voltage	$V_{i\text{ nom}}, 50\% I_{o\text{ nom}}$	4.95	5.0	5.05	3.267	3.3	3.333	VDC
$I_{o\text{ nom}}$	Nominal output current		20/25 <sup>1</sup>			20			A
$I_{o\text{ max}}$	Max. output current	$V_{i\text{ min}} - V_{i\text{ max}}$	40			40			
$I_{o\text{ L}}$	Output current limit	$T_{C\text{ min}} - T_{C\text{ max}}$	50			50			
$I_{o\text{ min}}$	Minimum load		no min. load required			no min. load required			
$v_o$	Output voltage noise <sup>4</sup>	Switch. frequ.	25			20			mV <sub>pp</sub>
		Total	60			60			
$\Delta V_{oV}$	Static line regulation	$V_{i\text{ min}} - V_{i\text{ max}}, I_{o\text{ nom}}$	$\pm 10$			$\pm 10$			mV
$\Delta V_{oL}$	Static load regulation	$V_{i\text{ nom}}, 50 - 100\% I_{o\text{ max}}$	$\pm 10$			$\pm 10$			
$\Delta V_{oS}$	Overshoot at switch on/off		0			0			
$v_{o\text{ d}}$	Dynamic load regulation	Voltage deviation	Vo1: $\Delta I_{o1} = 10\text{ A}, dI_{o1}/dt = 2\text{ A}/\mu\text{s}$ Vo2: $\Delta I_{o2} = 10\text{ A}, dI_{o2}/dt = 2\text{ A}/\mu\text{s}$			$\pm 120$			$\mu\text{s}$
$t_d$		Recovery time	100			100			
$\alpha V_o$	Temperature coefficient of output voltage	$T_{C\text{ min}} - T_{C\text{ max}}$ $0 - I_{o\text{ nom}}, V_{i\text{ min}} - V_{i\text{ max}}$	$\pm 0.3$			$\pm 0.2$			mV/K

Table 4b: Output data of CPD/CPA200 and CPD/CPA250

Output			Vo3 (+12 V)			Vo4 (-12 V)			Unit
Characteristics		Conditions	min	typ	max	min	typ	max	
$V_o$	Output voltage	$V_{i\text{ nom}}, 50\% I_{o\text{ nom}}$	11.88	12.0	12.12	-11.52	-12.0	-12.48	VDC
$I_{o\text{ nom}}$	Nominal output current		2.5/4 <sup>1</sup>			0.5/1 <sup>1</sup>			A
$I_{o\text{ max}}$	Max. output current	$V_{i\text{ min}} - V_{i\text{ max}}$	5.5			2			
$I_{o\text{ L}}$	Output current limit	$T_{C\text{ min}} - T_{C\text{ max}}$	7			3.5			
$I_{o\text{ min}}$	Minimum load		$I_{o3} > 75\% I_{o4}$ <sup>2</sup>			no min. load required			
$v_o$	Output voltage noise <sup>4</sup>	Switch. frequ.							mV <sub>pp</sub>
		Total	120			120			
$\Delta V_{oV}$	Static line regulation	$V_{i\text{ min}} - V_{i\text{ max}}, I_{o\text{ nom}}$	$\pm 10$			$\pm 10$			mV
$\Delta V_{oL}$	Static load regulation	$V_{i\text{ nom}}, I_o = 1 - 2\text{ A}$	$\pm 30$			-380 <sup>3</sup>			
$\Delta V_{oS}$	Overshoot at switch on/off		0			0			
$v_{o\text{ d}}$	Dynamic load regulation	Voltage deviation	Vo3: $\Delta I_{o3} = 2\text{ A}, dI_{o3}/dt = 2\text{ A}/\mu\text{s}$ Vo4: $\Delta I_{o4} = 0.5\text{ A}, dI_{o4}/dt = 2\text{ A}/\mu\text{s}$			$\pm 200$			$\mu\text{s}$
$t_d$		Recovery time	500			500			
$\alpha V_o$	Temperature coefficient of output voltage	$T_{C\text{ min}} - T_{C\text{ max}}$ $0 - I_{o\text{ nom}}, V_{i\text{ min}} - V_{i\text{ max}}$	$\pm 0.3$			$\pm 0.5$			mV/K

<sup>1</sup> First value for CPD200/CPA200, second value for CPD250/CPA250

<sup>2</sup> Minimum load is only required to maintain regulation of Vo4

<sup>3</sup> Droop characteristic for passive current sharing

<sup>4</sup> Measured with a probe according to IEC/EN 61204, annex A

General Conditions:

- $T_A = 25\text{ }^\circ\text{C}$ , unless  $T_C$  is specified.
- CPA500/550: 300 LFM (1.5 m/s)
- Sense lines connected directly at the connector

Table 5a: Output data of CPA500 and CPA550

Output			Vo1 (5.0 V)			Vo2 (3.3 V)			Unit
Characteristics		Conditions	min	typ	max	min	typ	max	
$V_o$	Output voltage	$V_{i\text{ nom}}, 50\% I_{o\text{ nom}}$	4.95	5.0	5.05	3.267	3.3	3.333	VDC
$I_{o\text{ nom}}$	Nominal output current		40/50 <sup>1</sup>			50/60 <sup>1</sup>			A
$I_{o\text{ max}}$	Max. output current	$V_{i\text{ min}} - V_{i\text{ max}}$	50			60			
$I_{o\text{ L}}$	Output current limit	$T_{C\text{ min}} - T_{C\text{ max}}$	52.2	62		63	74		
$I_{o\text{ min}}$	Minimum load		no min. load required			no min. load required			mV <sub>pp</sub>
$v_o$	Output voltage noise <sup>4</sup>	Switch. frequ.	$V_{i\text{ nom}}, I_{o\text{ nom}}$ BW = 20 MHz <sup>4</sup>			15			
		Total	$C_{\text{ext}} = 22\text{ }\mu\text{F} + 100\text{ nF}$			15			
$\Delta V_{oV}$	Static line regulation	$V_{i\text{ min}} - V_{i\text{ max}}, I_{o\text{ nom}}$	±10			±10			mV
$\Delta V_{oL}$	Static load regulation	$V_{i\text{ nom}}, 50 - 100\% I_{o\text{ max}}$	±10			±10			
$\Delta V_{oS}$	Overshoot at switch on/off		0			0			
$v_{o\text{ d}}$	Dynamic load regulation	Voltage deviation	Vo1: $\Delta I_{o1} = 20\text{ A}, dI_{o1}/dt = 2\text{ A}/\mu\text{s}$ Vo2: $\Delta I_{o2} = 40\text{ A}, dI_{o2}/dt = 2\text{ A}/\mu\text{s}$			±150			±150
$t_d$		Recovery time	300			300			
$\alpha V_o$	Temperature coefficient of output voltage	$T_{C\text{ min}} - T_{C\text{ max}}$ $0 - I_{o\text{ nom}}, V_{i\text{ min}} - V_{i\text{ max}}$	±0.3			±0.2			mV/K

Table 5b: Output data of CPA500 and CPA550

Output			Vo3 (+12 V)			Vo4 (-12 V)			Unit
Characteristics		Conditions	min	typ	max	min	typ	max	
$V_o$	Output voltage	$V_{i\text{ nom}}, 50\% I_{o\text{ nom}}$	11.88	12.0	12.12	-11.52	-12.0	-12.48	VDC
$I_{o\text{ nom}}$	Nominal output current		8			3			A
$I_{o\text{ max}}$	Max. output current	$V_{i\text{ min}} - V_{i\text{ max}}$	12			4			
$I_{o\text{ L}}$	Output current limit	$T_{C\text{ min}} - T_{C\text{ max}}$	13.5			4.3			
$I_{o\text{ min}}$	Minimum load		$I_{o3} > 75\% I_{o4}$ <sup>2</sup>			no min. load required			mV <sub>pp</sub>
$v_o$	Output voltage noise <sup>4</sup>	Switch. frequ.	$V_{i\text{ nom}}, I_{o\text{ nom}}$ BW = 20 MHz <sup>4</sup>			10			
		Total	$C_{\text{ext}} = 22\text{ }\mu\text{F} + 100\text{ nF}$			15			
$\Delta V_{oV}$	Static line regulation	$V_{i\text{ min}} - V_{i\text{ max}}, I_{o\text{ nom}}$	±10			±10			mV
$\Delta V_{oL}$	Static load regulation	$V_{i\text{ nom}}, I_o = 2 - 4\text{ A}$	±50			-220 <sup>3</sup>			
$\Delta V_{oS}$	Overshoot at switch on/off		0			0			
$v_{o\text{ d}}$	Dynamic load regulation	Voltage deviation	Vo3: $\Delta I_{o3} = 4\text{ A}, dI_{o3}/dt = 2\text{ A}/\mu\text{s}$ Vo4: $\Delta I_{o4} = 1\text{ A}, dI_{o4}/dt = 2\text{ A}/\mu\text{s}$			±200			±150
$t_d$		Recovery time	300			300			
$\alpha V_o$	Temperature coefficient of output voltage	$T_{C\text{ min}} - T_{C\text{ max}}$ $0 - I_{o\text{ nom}}, V_{i\text{ min}} - V_{i\text{ max}}$	±0.3			±0.5			mV/K

<sup>1</sup> First value for CPA500, second value for CPA550

<sup>2</sup> Minimum load is only required to maintain regulation of Vo4

<sup>3</sup> Droop characteristic for passive current sharing

<sup>4</sup> Measured with a probe according to IEC/EN 61204, annex A

### Hold-up Time of CPD Models

For extended hold-up time of CPD models, use external output capacitors or decoupling diodes and input capacitors of adequate size.

Formula for additional external input capacitor:

$$C_{i\text{ ext}} = \frac{2 \cdot P_o \cdot (t_{h\text{ total}} - t_h) \cdot 100}{\eta \cdot (V_{ti}^2 - V_{i\text{ min}}^2)}$$

where as:

- $C_{i\text{ ext}}$  = external input capacitance [mF]
- $P_o$  = output power [W]
- $\eta$  = efficiency [%]
- $t_{h\text{ total}}$  = total hold-up time [ms]
- $t_h$  = hold-up time [ms]
- $V_{i\text{ min}}$  = minimum input voltage [V]
- $V_{ti}$  = threshold level [V]

### Hot Swap

Hot swap is possible. Using the hot-swap capability, the output voltages may deviate dynamically by a maximum of 5% during the plug-in / plug-out operations.

### Output Protection and Current Limitation

All outputs are fully protected against continuous open-circuit (no load) and continuous short-circuit conditions.

All outputs of CPx200/250 models have a constant current limitation with a rectangular characteristic (see figure below). In addition, the total power from outputs Vo1, Vo2, and Vo3 is limited to  $P_{o\text{ max}}$ . So there is a free choice of load distribution between these outputs. Output Vo4 is disabled in the case of overtemperature generated by overcurrent.

In CPA500/550 models, the total power of all four outputs is limited to  $P_{o\text{ max}}$ .

In all models, all outputs are monitored for overvoltage condition. In such a case, the converter is permanently disabled. To reset, the input voltage must be removed for at least 60 seconds.

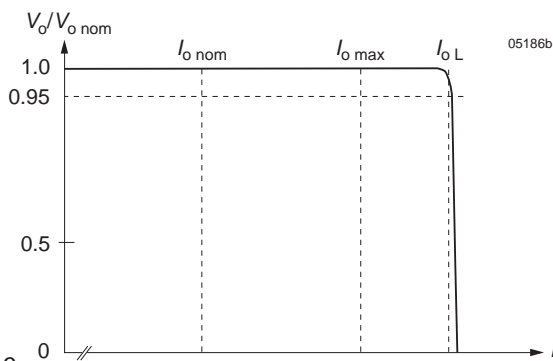

Fig. 3  
Typical output characteristic  $V_o$  versus  $I_o$

### Thermal Considerations

If a converter is mounted in an upright position with airflow as specified in the general conditions of table 4 allowing unrestricted forced-air cooling, and is operated at its

nominal input voltage and power at maximum ambient temperature  $T_{A\text{ max}}$  (see *Temperatures*), the temperature measured at the measurement point of the case temperature  $T_C$  (see *Mechanical Data*) will approach the indicated maximum value  $T_{C\text{ max}}$  (105 °C) after an initial warm-up phase. However, the relationship between  $T_A$  and  $T_C$  depends heavily on the operating conditions and system integration. The thermal conditions are influenced significantly by the input voltage, the output current, the airflow, and the temperature of the adjacent elements and surfaces.  $T_{A\text{ max}}$  is therefore only an indicative value (contrary to  $T_{C\text{ max}}$ ).

**Caution:** The installer must ensure that under all operating conditions  $T_C$  remains within the limits shown in the diagrams fig. 3, which is valid for a converter mounted in free and quasi-stationary air, allowing unrestricted convection cooling.

**Note:** Forced-air cooling or an additional heat sink can improve the reliability or allow  $T_A$  to be increased above  $T_{A\text{ max}}$  provided that  $T_{C\text{ max}}$  is not exceeded.

### Thermal Protection

A temperature sensor fitted on the main PCB provides an overtemperature warning (degrade) signal 15 °C below the

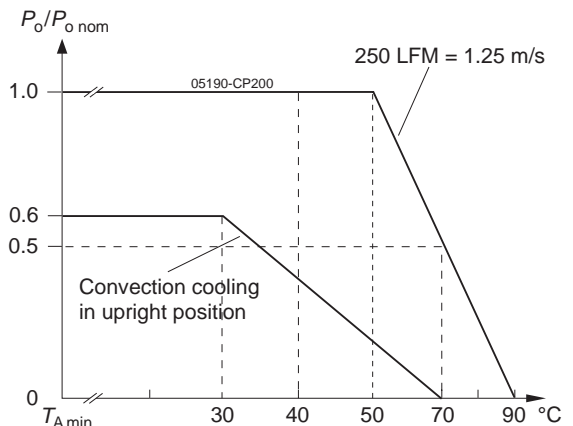

Fig. 4a  
Output power versus temperature  $T_A$  (CPD/CPA200)

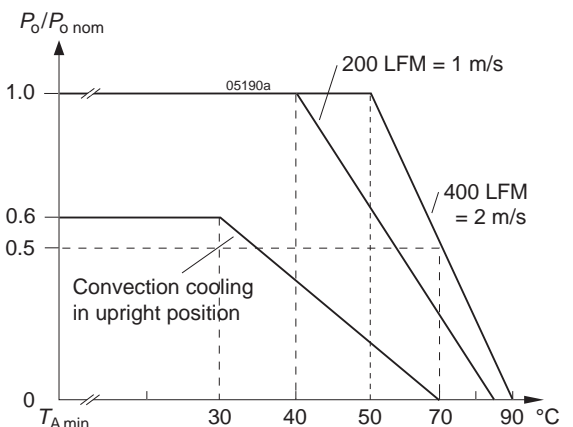

Fig. 4b  
Output power versus temperature  $T_A$  (CPD/CPA250)

temperature  $T_{C,max}$ , at which the thermal derating begins to reduce the output power. The output power returns to the normal value, when the temperature drops back below this limit; see *Temperature Warning and Shut-Down*.

### Output Filter

The output ripple voltage can be reduced by an external filter to less than 5 mV<sub>pp</sub>. Recommended values:

- C1, C2: Low ESR capacitor, e.g., OS-CON 100 – 470 μF
- L1, L2: Choke 1 – 2.2 μH with appropriate rated current, e.g., Coiltronics<sup>®</sup> HC2LP 1 μH /33 A or 2.2 μH /24 A.

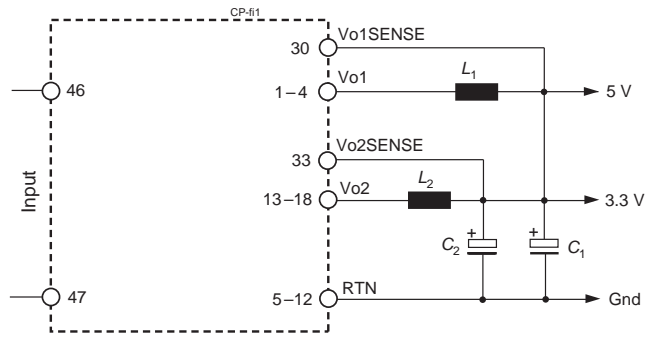

Fig. 5  
Output filter to reduce the output ripple of Vo1 and Vo2

## Auxiliary Functions

### Inhibit

The inhibit input enables (logic high, pull up) or disables (logic low, pull down) all outputs, if a logic signal (TTL, CMOS) is applied. In systems consisting of several converters this feature may be used to control the activation

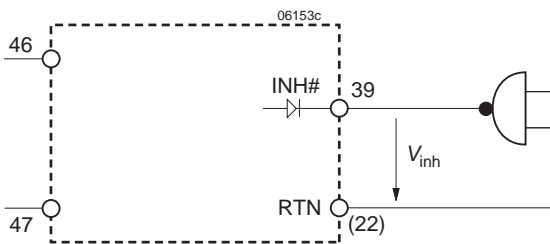

Fig. 6  
Definition of  $V_{inh}$ .

Table 6: Inhibit data

Characteristics		Conditions	min	typ	max	Unit
$V_{inh}$	Inhibit voltage	$V_o = \text{off}$	$V_{i \text{ min}} - V_{i \text{ max}}$	-2	0.8	V
		$V_o = \text{on}$	$I_o = 0 - I_{o \text{ max}}$	2.4	50	
$t_r$	Rise time				120	ms
$t_f$	Fall time				depending on $I_o$	

sequence of the converters by means of logic signals, or to enable the source to start-up, before full load is applied.

**Note:** If this function is not used, the inhibit pin 39 can be left open (not connected). If pin 39 is connected to a return pin (e.g., pin 24), the internal logic will disable all outputs. The inhibit input is protected by a decoupling diode.

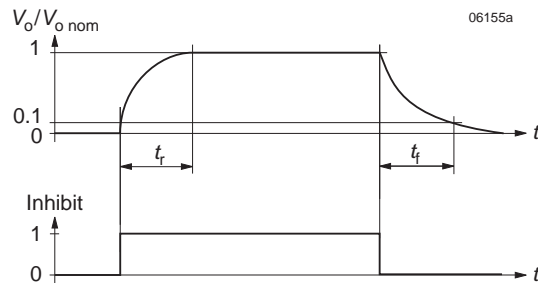

Fig. 7  
Typical output response as a function of inhibit voltage.

### Enable

Connect enable pin 27 (EN#) with signal return pin 22 (RTN) externally to start the converter. Pin 27 is shorter than the others ensuring startup only when all other pins are already connected to the system providing a true hot-swap capability.

### Temperature Warning and Shutdown

The temperature warning circuitry monitors the case temperature. Its output signal changes from high to low impedance, when the case temperature exceeds the upper threshold level, and changes back to high impedance, when the case temperature  $T_C$  falls below the lower threshold level, which is  $85\text{ }^\circ\text{C} \pm 5\text{ }^\circ\text{C}$ .

Pin 38 (degrade signal  $V_{\text{DEG}\#}$ ) is internally connected via the collector-emitter path of an NPN transistor to the signal return pin 22. The current  $I_{\text{DEG}\#}$  through pin 38 should not exceed 40 mA. To prevent the NPN transistor from damage,  $V_{\text{DEG}\#}$  should not exceed 40 V.

If the case temperature  $T_C$  exceeds  $105\text{ }^\circ\text{C}$ , the converter will be disabled. It resumes operation, once  $T_C$  falls below  $105\text{ }^\circ\text{C}$ .

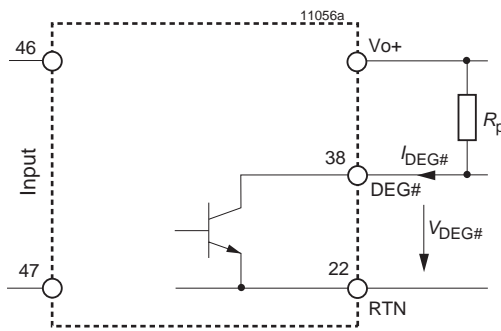

Fig. 8  
Degrade signal: NPN output  $V_{\text{DEG}\#} \leq 40\text{ V}$ ,  $I_{\text{DEG}\#} \leq 20\text{ mA}$

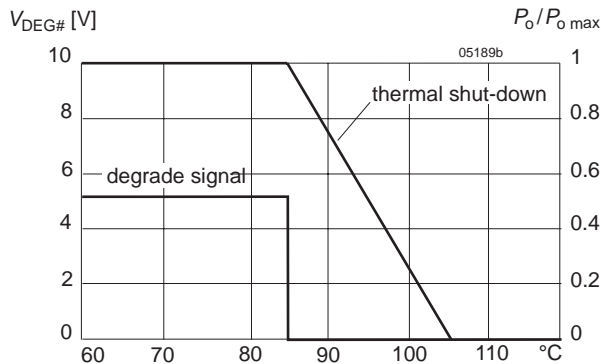

Fig. 9  
Degrade signal  $V_{\text{DEG}\#}$  versus case temperature  $T_C$

### Power Fail Signal

The power fail circuitry monitors the input voltage and all output voltages. Its output signal  $\overline{V_{\text{fail}}}$  changes from high to low impedance, when one of the monitored voltages falls below the threshold level;  $\overline{V_{\text{fail}}}$  changes back to high

impedance, when the monitored voltage exceeds the threshold level again.

The threshold levels correspond to approx. 90%  $V_{i\text{min}}$  and approx. 85%  $V_{o\text{nom}}$ .

Connector pin 42 (signal  $\overline{V_{\text{fail}}}$ ) is internally connected via the drain-source path of a JFET (self-conducting type) to the signal return pin 22. The current  $I_{\text{fail}}$  should not exceed 2.5 mA. The JFET is not protected against overvoltage;  $V_{\text{fail}}$  should not exceed 40 V.

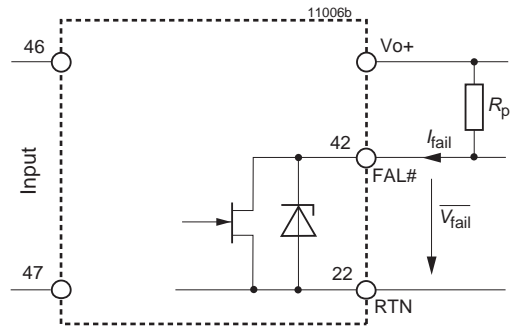

Fig. 10  
Power Fail: JFET output,  $I_{\text{fail}} \leq 2.5\text{ mA}$

### Sense Lines

(Only for Vo1, Vo2, and Vo3.)

This feature allows the compensation of voltage drops across the connector contacts and if necessary, across the load lines.

To ensure correct operation, all sense lines S+ (Vo1SENSE, Vo2SENSE, and Vo3SENSE) should be connected to the respective power outputs. The common sense return S- (SRTN) should be connected to RTN (pin 5 – 12).

**Note:** Open sense lines are admissible, but the output voltage regulation will be poor.

The voltage difference between any sense line at its respective power output pin (as measured on the connector) should not exceed the following values.

**Note:** If the sense lines S+ and S- compensate for a considerable voltage drop, the output loads shall be reduced in order to respect the maximum output power.

Table 7: Sense line data

Output [V]	Total voltage difference between sense lines and their respective outputs
3.3	0.8 V
5	1 V
12	1 V

### Active Current Sharing for Vo1, Vo2, Vo3

The current sharing facility, consisting of a single-wire link, should be used, where several converters are operated in parallel connection, for example, high reliability n+1 redundant systems or systems providing higher output power. Not more than six converters should be connected in parallel.

Using this feature reduces the stress of the individual converters and improves the reliability of the system. Interconnection of the current sharing terminals causes the converters to share the output current evenly. In n+1 redundant systems a failure of a single converter will not lead to a system failure, since the outputs are already decoupled by FETs and diodes internally.

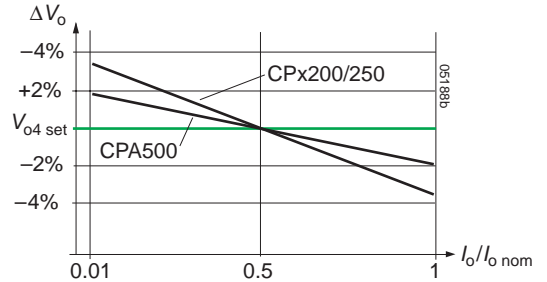

Fig. 11  
Output voltage  $V_{o4}$  versus output current  $I_{o4}$ .

### Passive Current Sharing for Vo4

The output voltage changes slightly with the output current (droop characteristic) ensuring automatic current sharing without further precautions, when several converters are connected in parallel. An increase in output current decreases the output voltage according to fig. 11.

### LEDs

A green LED "Input OK" and a red LED "Fault" are incorporated in the front panel.

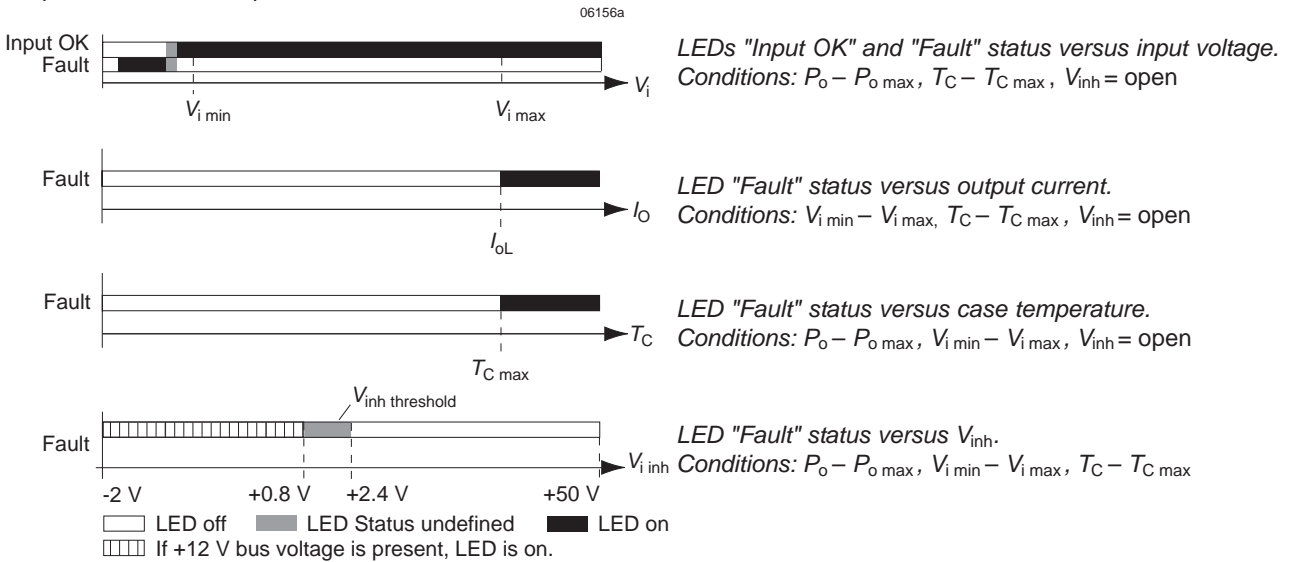

Fig. 12  
Display status of LEDs

## Electromagnetic Compatibility (EMC)

A metal oxide VDR together with an input fuse and filter form an effective protection against high input voltage transients ,

which typically occur in most installations. The CPD Series has been successfully tested to the following specifications:

## Electromagnetic Immunity

Table 8: Immunity type tests

Phenomenon	Standard	Level	Coupling mode <sup>1</sup>	Value applied	Waveform	Source imped.	Test procedure	In oper.	Per-form. <sup>2</sup>
Electrostatic discharge (to case)	IEC/EN 61000-4-2	4	contact discharge	8000 V <sub>p</sub>	1/50 ns	330 Ω	10 positive and 10 negative discharges	yes	A
			air discharge	15000 V <sub>p</sub>					
Electromagnetic field	IEC/EN 61000-4-3	3	antenna	10 V/m	AM 80% 1 kHz	n.a.	80 – 1000 MHz	yes	A
				10 V/m	50% duty cycle 200 Hz repetition frequency		900 ±5 MHz		
Electrical fast transients/burst	IEC/EN 61000-4-4	3	capacitive, o/c	1000 V <sub>p</sub>	bursts of 5/50 ns 2.5/5 kHz over 15 ms; burst period: 300 ms	50 Ω	60 s positive 60 s negative transients per coupling mode	yes	A
			direct, i/c, +i/-i	2000 V <sub>p</sub>					
Surges	IEC/EN 61000-4-5	3	i/c	2000 V <sub>p</sub>	1.2/50 μs	12 Ω	5 pos. and 5 neg. surges per coupling mode	yes	B
		2	+i/-i	1000 V <sub>p</sub>		2 Ω			
Conducted disturbances	IEC/EN 61000-4-6	3	i, o, signal wires	10 VAC (140 dBμV)	AM 80% 1 kHz	150 Ω	0.15 – 80 MHz	yes	A

<sup>1</sup> i = input, o = output, c = case connected to PE ⊕

<sup>2</sup> A = normal operation, no deviation from specifications, B = temporary deviation from specs possible.

**Electromagnetic Emission**

Radiated and conducted emissions comply with EN 55011/55022, class A. In addition, CPA500/550 meet conducted emissions class B.

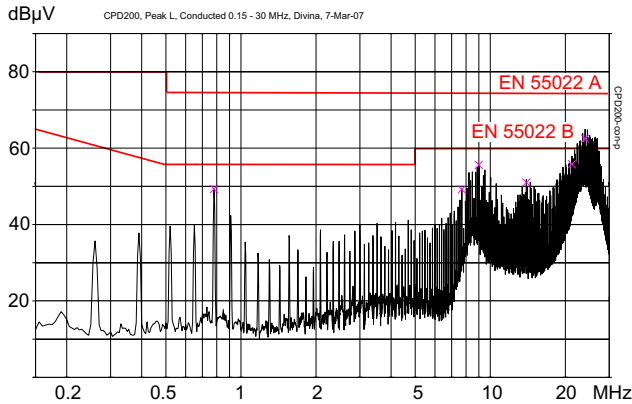

**Fig. 13a**  
Typical disturbance voltage (peak) at the negative input according to EN 55022, measured at  $V_{i,nom}$  and  $I_{o,nom}$  (CPD200-4530).

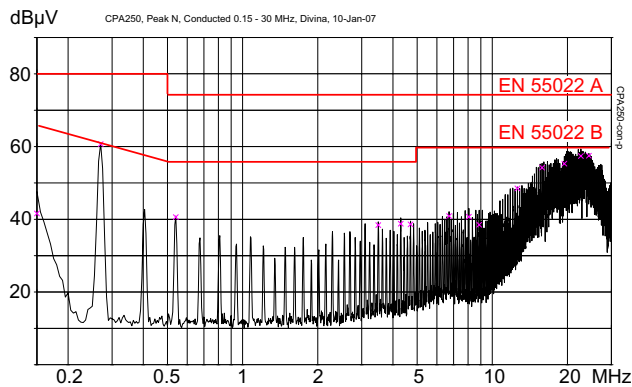

**Fig. 13b**  
Typical disturbance voltage (peak) at the line input according to EN 55022, measured at  $V_{i,nom}$  and  $I_{o,nom}$  (CPA250-4530).

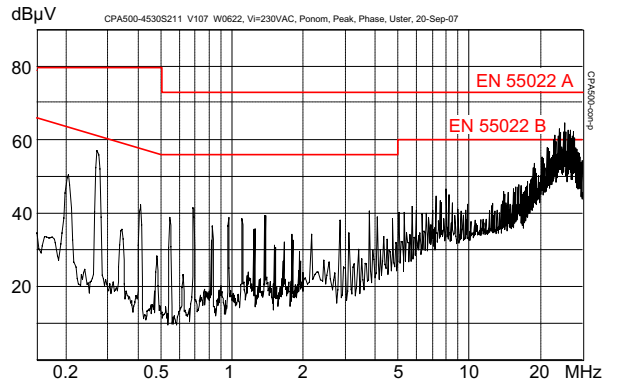

**Fig. 13c**  
Typical disturbance voltage (peak) at the line input according to EN 55022, measured at  $V_{i,nom}$  and  $I_{o,nom}$  (CPA500-4530).

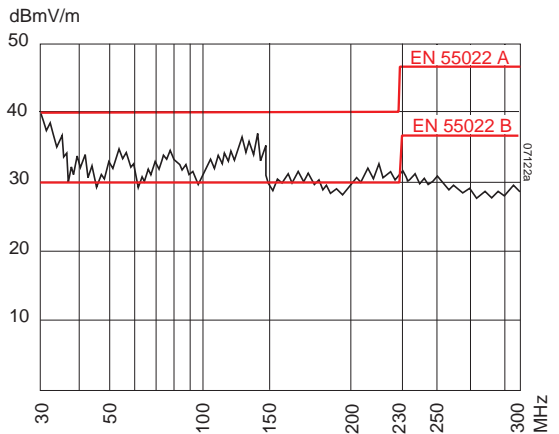

**Fig. 14**  
Typical radiated electromagnetic field strength (quasi peak) according to EN 55022, normalised to a distance of 10 m, measured at  $V_{i,nom}$  and  $I_{o,nom}$ .

## Immunity to Environmental Conditions

Table 9: Mechanical and climatic stress

Test method		Standard	Test conditions		Status
Cab	Damp heat steady state	IEC/EN 60068-2-78	Temperature: Relative humidity: Duration:	40 ±2 °C 93 +2/-3 % 56 days	Converter not operating
Ea	Shock (half-sinusoidal)	IEC/EN 60068-2-27	Acceleration amplitude: Bump duration: Number of bumps:	20 g <sub>n</sub> 11 ms 18 (3 in each direction)	Converter operating
Eb	Bump (half-sinusoidal)	IEC/EN 60068-2-29	Acceleration amplitude: Bump duration: Number of bumps:	15 g <sub>n</sub> 6 ms 6000 (1000 in each direction)	Converter operating
Fda	Random vibration wide band, reproducibility high	IEC/EN 60068-2-35 CPD200/250, CPA200/250	Acceleration spectral density: Frequency band: Acceleration magnitude: Test duration:	0.05 g <sub>n</sub> <sup>2</sup> /Hz 20 – 500 Hz 4.9 g <sub>n rms</sub> 3 h (1 h in each axis)	Converter operating
		IEC/EN 60068-2-35 CPA500/550	Acceleration spectral density: Frequency band: Acceleration magnitude: Test duration:	0.01 g <sub>n</sub> <sup>2</sup> /Hz 20 – 500 Hz 2.2 g <sub>n rms</sub> 1.5 h (0.5 h in each axis)	Converter operating
	Drop test	Converter in proper packing CPD <sup>1</sup> only	0.75 m	3 directions	Not operating

<sup>1</sup> Version V106 or higher

## Temperatures

Table 10: Temperature specifications, valid for an air pressure of 800 – 1200 hPa (800 – 1200 mbar)

Characteristics		Conditions	Relative humidity <sup>3</sup> [%]			Temperature [°C]		
			min	typ	max	min	typ	max
T <sub>A</sub>	Ambient temperature	Operational <sup>1</sup>	5		95	-25		50
T <sub>C</sub>	Case temperature <sup>2</sup>		5		95	-25		105 <sup>2</sup>
T <sub>S</sub>	Storage temperature	Non operational	10		95	-40		85
R <sub>th C-A</sub>	Thermal resistance case to ambient in still air		2 K/W					

<sup>1</sup> See *Thermal Considerations*

<sup>2</sup> Overtemperature shutdown at T<sub>C</sub> ≥ 105 °C

<sup>3</sup> Non condensing humidity

## Reliability

Table 11: MTBF

Ratings at specified case temperature	Model	Ground benign 40 °C	Ground fixed		Ground mobile 50 °C	Unit
			40 °C	70 °C		
MTBF acc. to MIL-HDBK-217F, notice 2	CPD250	288 000	59 000	33 000	27 000	h
	CPA250	279 000	57 000	31 000	33 000	
	CPA500	195 000	35 000	17 000	16 000	

**Mechanical Data**

Dimensions in mm.

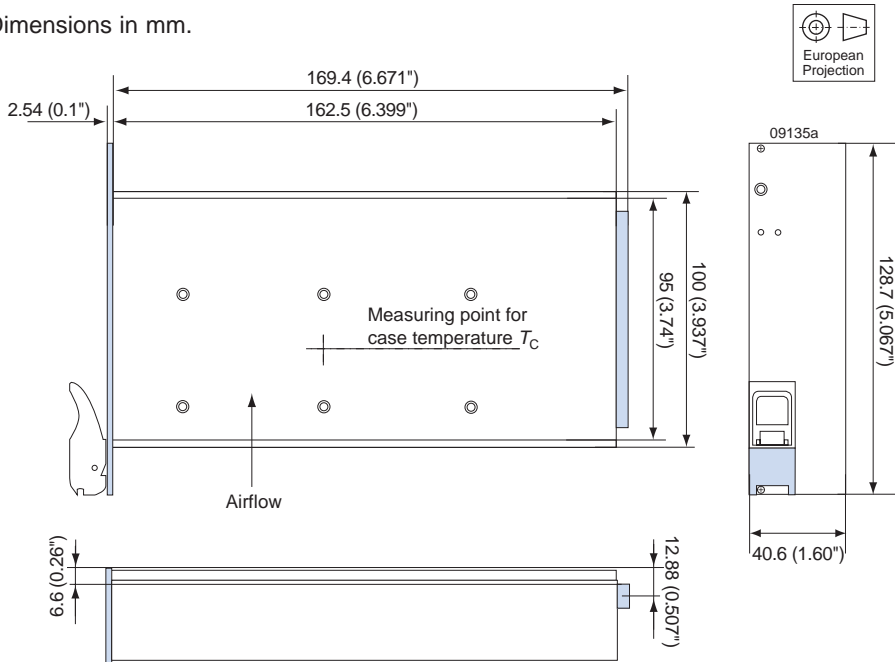

Fig. 15  
Overall size: 162.5 mm x 128.7 mm x 40.6 mm  
Weight: 0.8 kg



Fig. 16  
View of the front connector

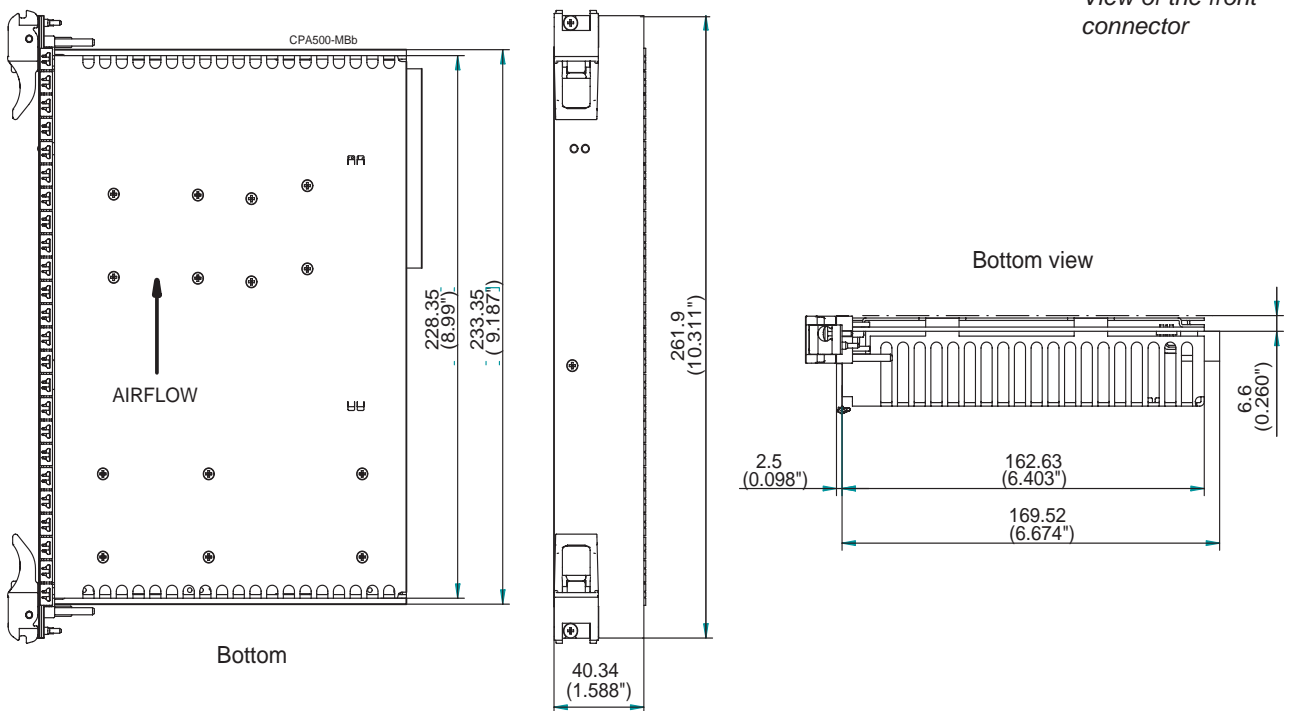

Fig. 17  
Overall size: 223.4 mm x 162.5 mm x 40.6 mm  
Weight: 1.65 kg

## Safety and Installation Instructions

### Connector Pin Allocation

The connector pin allocation table defines the electrical potentials and the physical pin positions on the Positronic connector. Pin no. 45 (protective earth) is a leading pin, ensuring that it makes contact with the female connector first.

Table 12: Pin allocation of the front connector

Pin <sup>1</sup>	Length <sup>2</sup>	Signal name	Description
1-4	B	Vo1	Output 1
5-12	B	RTN	Return (Vo1 and Vo2)
13-18	B	Vo2	Output 2
19	B	RTN	Return (Vo3)
20	B	Vo3	Output 3
21	C	Vo4	Output 4
22	C	RTN	Return
23	C	Reserved	Reserved
24	C	RTN	Return (Vo4)
25	C	n.c.	Do not connect
26	C	Reserved	Reserved
27	D	EN#	Enable
28	C	n.c.	Do not connect
29	C	n.c.	Do not connect
30	C	Vo1SENSE	Vo1 remote sense
31	C	n.c.	Do not connect

<sup>1</sup> Pin numbers shown are for the female backplane connector

<sup>2</sup> A = very long pins, B = long pins, C = short pins, D = very short pins.

<sup>3</sup> Pin 45 of the female connector is leading, ensuring that chassis ground makes contact first.

<sup>4</sup> CPD models (DC input)

<sup>5</sup> CPA models (AC input)

### Installation Instructions

These converters are components, intended exclusively for installation within other equipment by an industrial assembly process or by a professionally, competent person. Installation must strictly follow the national safety regulations in respect of the enclosure, mounting, creepage distances, clearance, casualty markings, and segregation requirements of the end-use application.

Connection to the system shall be made via the mating female connector (see fig. 16). Other installation methods may not meet the safety requirements. Check for hazardous voltage before altering any connections.

The converters are provided with a leading pin no. 45, which is reliably connected to the case. For safety reasons it is essential to connect this pin to the protective earth of the supply system; see also *Safety of Operator-Accessible Output Circuits*.

The Vi input (pin no. 46) is internally fused. This fuse is designed to protect the converter in case of over current,

Connector: Positronic PCIH47M400A1 or similar

Mating female connector: Positronic PCIH47F300A1 or similar

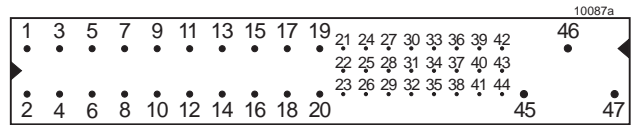

Fig. 18

Pinout of the front connector

Pin <sup>1</sup>	Length <sup>2</sup>	Signal name	Description
32	C	n.c.	Do not connect
33	C	Vo2SENSE	Vo2 remote sense
34	C	SRTN	Sense return
35	C	Vo1SHARE	Vo1 current share
36	C	Vo3SENSE	Vo3 remote sense
37	C	n.c.	Do not connect
38	C	DEG#	Degrade signal
39	C	INH#	Inhibit
40	C	n.c.	Do not connect
41	C	Vo2SHARE	Vo2 current share
42	C	FAL#	Fail signal
43	C	n.c.	Do not connect
44	C	Vo3SHARE	Vo3 current share
45	A <sup>3</sup>	CGND	Chassis ground
46	A	+DCIN <sup>4</sup> ACN <sup>5</sup>	Positive input <sup>4</sup> Neutral line <sup>5</sup>
47	A	-DCIN <sup>4</sup> ACL <sup>5</sup>	Negative input <sup>4</sup> Line input(phase) <sup>5</sup>

but may not be able to satisfy all customer requirements. External fuses in the wiring to one or both input pins (no. 46 and/or no. 47) may therefore be necessary to ensure compliance with local requirements.

**Important:** If the inhibit function is not used, pin 39 (i) should be left unconnected to enable the outputs. Enable Pin 27 (EN#) should be connected to pin 22 (RTN) to enable the outputs.

Do not open the converters, or the warranty will be invalidated. Make sure that there is sufficient airflow available for convection cooling. This should be verified by measuring the case temperature, when the converter is installed and operated in the end-use application. The maximum specified case temperature  $T_{C\ max}$  should not be exceeded.

Make sure that a converter failure (e.g., by an internal short-circuit) does not result in a hazardous condition.

### Standards and Approvals

The converters correspond to class I equipment.

All converters are approved according to UL 60950-1, CSA 60950-1, IEC 60950-1, and EN 60950-1.

The converters correspond to Class I equipment. The following considerations have been made during design concerning safety:

- Build-in component
- Basic insulation between input and output, based on 75 VDC. The input is identified as TNV-2.
- Operational insulation between output(s) and case
- Use in a pollution degree 2 environment.

The converters are subject to manufacturing surveillance in accordance with the above mentioned UL standards and ISO 9001:2000.

### Cleaning Agents

The power supplies are not hermetically sealed. In order to avoid possible damage, any penetration of cleaning fluids shall be avoided.

### Protection Degree

The converters correspond to protection degree IP 20, provided that the female connector is fitted.

### Isolation

The electric strength test is performed as factory test in accordance with EN 50116 and EN/IEC 60950 and should not be repeated in the field (see table *Isolation*). Power-One will not honor any warranty claims resulting from electric strength field tests.

### Safety of Operator-Accessible Output Circuits

If the output circuit of a converter is operator-accessible, it shall be an SELV circuit according to the IEC/EN 60950 related safety standards.

However, it is the sole responsibility of the installer to ensure the compliance with the relevant and applicable safety regulations.

Table 13: Isolation

Characteristic		CPD models		CPA models		Unit
		Input to (case + output)	Output to case	Input to (case + output)	Output to case	
Electric strength test	Actual factory test $\geq 1$ s	1500 <sup>1</sup>	700	2200 <sup>2</sup>	700 <sup>2</sup>	VDC
	AC test voltage equivalent to factory test	1000	500	1550 <sup>2</sup>	500 <sup>2</sup>	VAC
Insulation resistance at 500 VDC		>300	>300	>300	>300	MΩ

<sup>1</sup> According to IEC/EN 60950, subassemblies connecting input to output are pre-tested with  $\geq 3$  kVDC.

<sup>2</sup> According to IEC/EN 60950, subassemblies connecting input to output are pre-tested with  $\geq 4.3$  kVDC

NUCLEAR AND MEDICAL APPLICATIONS - Power-One products are not designed, intended for use in, or authorized for use as critical components in life support systems, equipment used in hazardous environments, or nuclear control systems without the express written consent of the respective divisional president of Power-One, Inc.

TECHNICAL REVISIONS - The appearance of products, including safety agency certifications pictured on labels, may change depending on the date manufactured. Specifications are subject to change without notice.

## EC Declaration of Conformity

### CE MARKING

We, **Power-One, Inc., 740 Calle Plano, Camarillo, CA. 93012 USA**  
declare under our sole responsibility that the products;

**Power Supply Model: CPD200 and CPD250 Series**

to which this declaration relates, is/are in compliance with the following document(s):

Quality Standard(s): **ISO 9001, EN 29001**

Directive: **DIR 73/23/EEC, Low Voltage Directive**

Product Safety Standard(s): **EN 60950-1: 2001**  
**IEC 60950-1: 2001**  
(Licensed by a Notified Body to the European Union )

These component level power supplies are intended exclusively for inclusion within other equipment by an industrial assembly operation or by professional installers per the Installation Instructions provided with the power supplies. The power supply is considered Class I and must be connected to a reliable earth grounding system.



*(Manufacturer)*

Robert P. White Jr.  
Product Safety Director

**Camarillo, Ca.**

*(Place)*

**October 24, 2006**

*(Date)*

## EC Declaration of Conformity

### CE MARKING

We, **Power-One, Inc., 740 Calle Plano, Camarillo, CA. 93012 USA**  
declare under our sole responsibility that the products;

**Power Supply Model: CPA200, CPA250, and CPA500 Series**

to which this declaration relates, is/are in compliance with the following document(s):

Quality Standard(s): **ISO 9001, EN 29001**

Directive: **DIR 73/23/EEC, Low Voltage Directive**

Product Safety Standard(s): **EN 60950-1: 2001**  
**IEC 60950-1: 2001**

(Licensed by a Notified Body to the European Union )

These component level power supplies are intended exclusively for inclusion within other equipment by an industrial assembly operation or by professional installers per the Installation Instructions provided with the power supplies. The power supply is considered Class I and must be connected to a reliable earth grounding system.



(Manufacturer)

Robert P. White Jr.  
Product Safety Manager

**Camarillo, Ca.**

(Place)

**March 31, 2005**

(Date)